

# OSRAM KRTBI D2LM31.31

## 产品规格书

Published by **ams-OSRAM AG**

Tobelbader Strasse 30, 8141 Premstaetten, Austria

Phone +43 3136 500-0

[ams-osram.com](http://ams-osram.com)

© All rights reserved



OSIRE™ E3731i

# KRTBI D2LM31.31

该产品是专门为要求高动态RGB照明场景的汽车内饰应用而设计的。该智能RGB产品除了R/G/B LED外，还集成了ams OSRAM的IC，这个嵌入式IC集成了三个R/G/B LED的驱动程序，还包括了R/G/B LED的光学测量数据。外部微控制器可以通过开放系统协议在菊花链拓扑结构寻址和控制每个LED。开放协议允许微控制器读取这些数据，并运行任何颜色算法。它还允许读取回一个温度值来优化这个颜色算法。OSIRE E3731i在所有汽车生产国均遵守已知的专利及知识产权合规。特别指出，该产品并无与LED封装内部执行温度补偿或者通过LED内置控制器进行SPI通信等已知专利的冲突。



## 应用

- 氛围灯

## 特点

- 封装: 白色SMD封装, 无色透明硅树脂
- 芯片技术: Thinfilm / ThinGaN
- 典型发光角度: 120° (朗伯发射体)
- 颜色:  $\lambda_{\text{dom}} = 626 \text{ nm}$  (● red);  $\lambda_{\text{dom}} = 533 \text{ nm}$  (● true green);  $\lambda_{\text{dom}} = 462 \text{ nm}$  (● blue)
- 防腐蚀级别: 3B
- 认证: AEC-Q102-003 Qualified
- ESD: 2 kV acc. to ANSI/ESDA/JEDEC JS-001 (HBM, Class 2); 500 V acc. to JESD22-C101 (CDM, Class C2)
- Optical measurement data available at two setpoints (10 and 50 mA)
- Serial data communication via open system protocol (OSP)
- Integrated  $\mu$ Driver
- Needs 5V DC supply voltage
- Auto addressing of package inside daisy chain

## 订购信息

型号	亮度组 <sup>1)</sup>	订单码
KRTBID2LM31.31-C5D7-JW+V9A5-J3+Q5S7-5V		Q65113A6249
• red	• $I_v = 320 \dots 900 \text{ mcd}$ ( $I_F = 10 \text{ mA}$ )	
• true green	• $I_v = 1000 \dots 2010 \text{ mcd}$ ( $I_F = 10 \text{ mA}$ )	
• blue	• $I_v = 80 \dots 355 \text{ mcd}$ ( $I_F = 10 \text{ mA}$ )	
KRTBID2LM31.31-1R-JW+1G-J3+1B-5V		Q65113A6250
• red	• $I_v = 320 \dots 900 \text{ mcd}$ ( $I_F = 10 \text{ mA}$ )	
• true green	• $I_v = 1000 \dots 2010 \text{ mcd}$ ( $I_F = 10 \text{ mA}$ )	
• blue	• $I_v = 125 \dots 400 \text{ mcd}$ ( $I_F = 10 \text{ mA}$ )	

## Typical brightness

$T_s = 25\text{ °C}$

Color	Current in mA	Value	Unit
● red	10	560	mcd
● true green	10	1460	mcd
● blue	10	220	mcd
● red	50	2520	mcd
● true green	50	4300	mcd
● blue	50	800	mcd

## Relative Luminous Intensity

$I_v(50\text{ mA})/I_v(10\text{ mA}) = f(I_F); T_s = 25\text{ °C}$

Color	Current in mA	Value
● red	50	4.5
● true green	50	2.95
● blue	50	3.65

## Dominant wavelength

$\Delta \lambda_{\text{dom}} = \lambda_{\text{dom}}(50\text{ mA}) - \lambda_{\text{dom}}(10\text{ mA}) = f(I_F); T_s = 25\text{ °C}$

Color	Current in mA	Value	Unit
● true green	50	-8	nm
● blue	50	-2	nm

## Absolute Maximum IC Ratings

Stresses beyond those listed under "Absolute Maximum Ratings" may cause permanent damage to the device. These are stress ratings only. Functional operation of the device at these or any other conditions beyond those indicated under "operation Conditions" is not implied. Exposure to absolute maximum rating conditions for extended periods may affect device reliability.

Parameter	Symbol	Values	
DC supply voltage <sup>1</sup>	$V_{DD}, V_{LED}$	min.	-0.3 V
		max.	7.0 V
SIO Voltage	$SIO1/2\_n/p$	min.	-0.3 V
		max.	$V_{DD} + 0.3 V$
Reverse voltage	$V_R$		Not designed for reverse operation
Operating Temperature	$T_{op}$	min.	-40 °C
		max.	110 °C
Storage Temperature	$T_{stg}$	min.	-40 °C
		max.	110 °C
Junction Temperature	$T_j$	min.	-40 °C
		max.	125 °C
ESD withstand voltage acc. to ANSI/ESDA/JEDEC JS-001 (HBM, Class 2)	$V_{ESD\_HBM}$	min.	-2 kV
		max.	2 kV
All Pads acc. to JESD22-C101 (CDM, Class C2)	$V_{ESD\_CDM}$	min.	-500 V
		max.	500 V

## Operating Conditions

Parameter	comment	Symbol	Values	
Power Supply Voltage (dc)	DC supply voltage IC and LED	$V_{DD}, V_{LED}$	min.	4.5 V
			max.	5.5 V
Startup time	Device ready for commands, time after VDD > VGOOD level	$t_{start}$	typ.	1 ms
Supply current IC at mode: (PIN: VDD IC, VDD = 5V)				
uninitialized state (after POR)			typ.	2.05 mA
ACTIVE mode	LED driver off	$I_{IC\_activ}$	typ.	2.05 mA
ACTIVE mode	LED driver on, PWM >=1, Current comparators of LED drivers: Avg. current Red*0.11 Avg. current Green*0.11 Avg. current Blue*0.11	$I_{IC\_LED\_ON}$	typ.	2.05+1.5 +avg current R,G,B *0.11 mA
SLEEP mode		$I_{IC\_sleep}$	typ.	2.05 mA
DEEPSLEEP mode		$I_{IC\_deep\_sleep}$	typ.	1.9 mA
Junction Temperature		$T_j$	min.	-40 °C
			max.	125 °C

## Start-up and power down description

Parameter	comment	Symbol	Values	
Deglitch time to detect Undervoltage		$t_{UV}$	typ.	50 us
Detection hysteresis		$V_{DET\_HYST}$	typ.	100 mV
VDD POR	address is lost	$V_{PoR}$	typ.	1.2 V
VDD communication stop		$V_{DD\_COM\_STOP}$	typ.	2.6 V
VDD under voltage level	LED driver are disabled at this level if selected	$V_{DD\_UVLO}$	min.	3.95 V
			max.	4.45 V
VDD normal voltage range		$V_{DD\_GOOD}$	min.	4.5 V
			max.	5.5 V

## 特性

$I_F = 10 \text{ mA}$ ;  $T_s = 25 \text{ }^\circ\text{C}$

参数	图形符号		值	值	值
			● red	● true green	● blue
峰值波长	$\lambda_{\text{peak}}$	典型值	635 nm	526 nm	456 nm
主波长 <sup>2)</sup>	$\lambda_{\text{dom}}$	最小值	620 nm	524 nm	449 nm
		典型值	626 nm	533 nm	462 nm
		最大值	632 nm	541 nm	473 nm
50% $I_V$ 发光角度	$2\varphi$	典型值	120 °	120 °	120 °
反向电流 <sup>3)</sup>	$I_R$		Not designed for reverse operation	Not designed for reverse operation	Not designed for reverse operation
实际热阻 PN结/焊点 <sup>4)</sup>	$R_{\text{thJS real}}$	典型值	75 K / W	49 K / W	49 K / W
		最大值	113 K / W	74 K / W	74 K / W

## Typical Dominant Wavelength<sup>1)</sup>

$T_s = 25 \text{ }^\circ\text{C}$

Color	Current in mA	Value	Unit
● red	10	626	nm
● true green	10	533	nm
● blue	10	462	nm
● red	50	626	nm
● true green	50	525	nm
● blue	50	460	nm

## 亮度组

发射颜色	组	发光强度 <sup>1)</sup> $I_F = 10 \text{ mA}$ 最小值 $I_v$	发光强度 <sup>1)</sup> $I_F = 10 \text{ mA}$ 最大值 $I_v$
• red	1R	320 mcd	900 mcd
• red	C5	320 mcd	500 mcd
• red	C7	360 mcd	560 mcd
• red	C9	400 mcd	630 mcd
• red	D	450 mcd	710 mcd
• red	D5	500 mcd	800 mcd
• red	D7	560 mcd	900 mcd
• true green	1G	1000 mcd	2010 mcd
• true green	V9	1000 mcd	1590 mcd
• true green	AW	1120 mcd	1800 mcd
• true green	A5	1250 mcd	2010 mcd
• blue	Q5	80 mcd	125 mcd
• blue	Q7	90 mcd	140 mcd
• blue	Q9	100 mcd	159 mcd
• blue	R	112 mcd	180 mcd
• blue	1B	125 mcd	400 mcd
• blue	R5	125 mcd	201 mcd
• blue	R7	140 mcd	224 mcd
• blue	R9	159 mcd	250 mcd
• blue	S	180 mcd	280 mcd
• blue	S5	201 mcd	315 mcd
• blue	S7	224 mcd	355 mcd

## 波长组

- red

组	主波长 <sup>2)</sup> 最小值 $\lambda_{\text{dom}}$	主波长 <sup>2)</sup> 最大值 $\lambda_{\text{dom}}$
JP	620 nm	625 nm
MT	623 nm	629 nm
RW	627 nm	632 nm

## 波长组

- true green

组	主波长 <sup>2)</sup> 最小值 $\lambda_{\text{dom}}$	主波长 <sup>2)</sup> 最大值 $\lambda_{\text{dom}}$
JP	524 nm	529 nm
LR	526 nm	531 nm
PU	529 nm	534 nm
RW	531 nm	536 nm
U3	534 nm	541 nm

## 波长组

- blue

组	主波长 <sup>2)</sup> 最小值 $\lambda_{\text{dom}}$	主波长 <sup>2)</sup> 最大值 $\lambda_{\text{dom}}$
51	449 nm	453 nm
3C	451 nm	456 nm
AF	454 nm	459 nm
DH	457 nm	461 nm
FK	459 nm	463 nm
HM	461 nm	465 nm
KP	463 nm	467 nm
MS	465 nm	470 nm
QV	468 nm	473 nm

色品坐标组

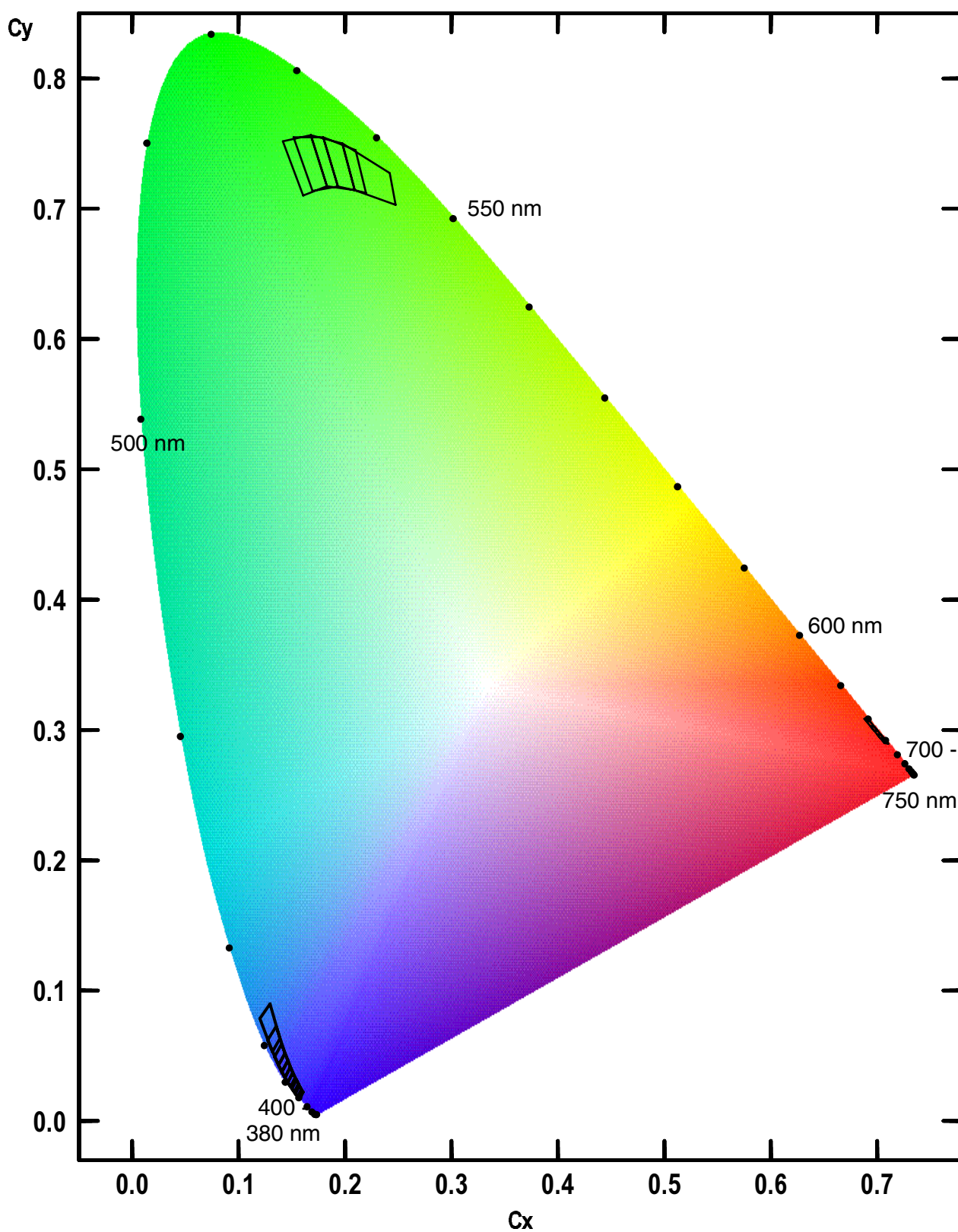

## 色度坐标组

● red

组	Cx	Cy
JP	0.6879	0.3086
	0.6915	0.3083
	0.7006	0.2993
	0.6969	0.2996
MT	0.6936	0.3030
	0.6972	0.3027
	0.7066	0.2934
	0.7028	0.2938
RW	0.7000	0.2966
	0.7037	0.2962
	0.7105	0.2895
	0.7067	0.2899

## 色度坐标组

● true green

组	Cx	Cy
JP	0.1606	0.7102
	0.1415	0.7518
	0.1679	0.7565
	0.1831	0.7174
LR	0.1694	0.7136
	0.1517	0.7547
	0.1794	0.7549
	0.1933	0.7170
PU	0.1831	0.7174
	0.1678	0.7565
	0.1973	0.7500
	0.2091	0.7142
RW	0.1932	0.7170
	0.1794	0.7549
	0.2098	0.7449
	0.2196	0.7122

## 色度坐标组

- true green

组	Cx	Cy
U3	0.2091	0.7142
	0.1974	0.7500
	0.2419	0.7273
	0.2474	0.7029

## 色度坐标组

- blue

组	Cx	Cy
3C	0.1588	0.0243
	0.1556	0.0186
	0.1500	0.0246
	0.1543	0.0317
51	0.1606	0.0222
	0.1576	0.0168
	0.1534	0.0206
	0.1570	0.0268
AF	0.1562	0.0285
	0.1524	0.0219
	0.1462	0.0293
	0.1509	0.0370
DH	0.1532	0.0332
	0.1489	0.0262
	0.1436	0.0332
	0.1487	0.0414
FK	0.1509	0.0370
	0.1462	0.0293
	0.1407	0.0376
	0.1463	0.0463
HM	0.1487	0.0414
	0.1436	0.0332
	0.1375	0.0428
	0.1436	0.0519

## 色度坐标组

- blue

组	Cx	Cy
KP	0.1463	0.0463
	0.1407	0.0376
	0.1338	0.0493
	0.1404	0.0588
MS	0.1436	0.0519
	0.1375	0.0428
	0.1272	0.0620
	0.1354	0.0727
QV	0.1389	0.0631
	0.1317	0.0532
	0.1199	0.0785
	0.1295	0.0899

相对光谱发射 <sup>5)</sup>

$I_{rel} = f(\lambda); I_F = 10 \text{ mA}; T_S = 25 \text{ }^\circ\text{C}$

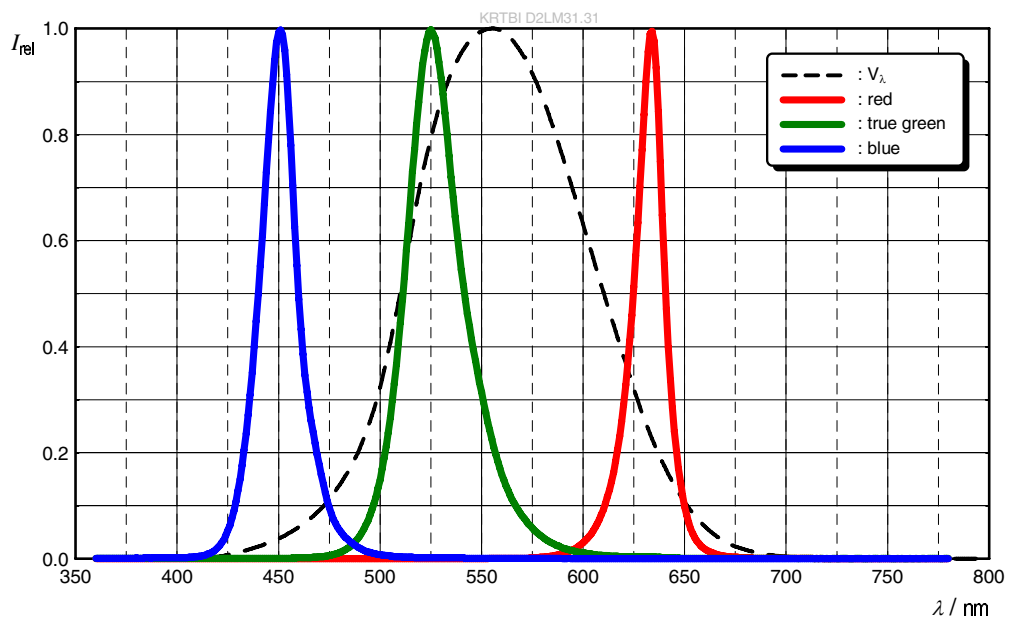

辐射特性 ( 水平 ) <sup>5)</sup>

$I_{rel} = f(\varphi); T_S = 25\text{ }^\circ\text{C}$

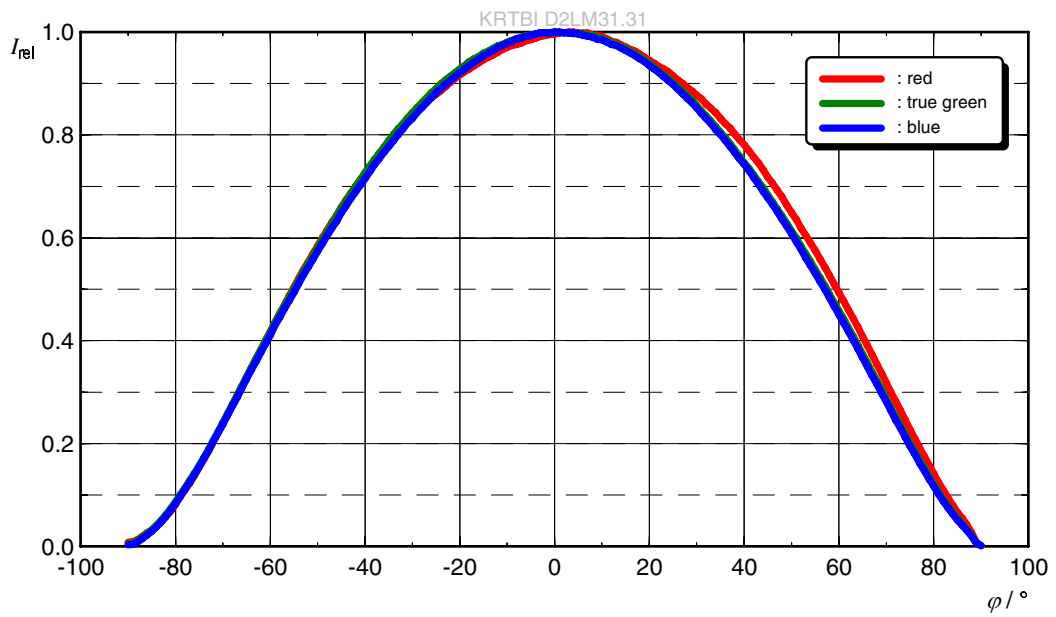

辐射特性 ( 垂直 ) <sup>5)</sup>

$I_{rel} = f(\varphi); T_S = 25\text{ }^\circ\text{C}$

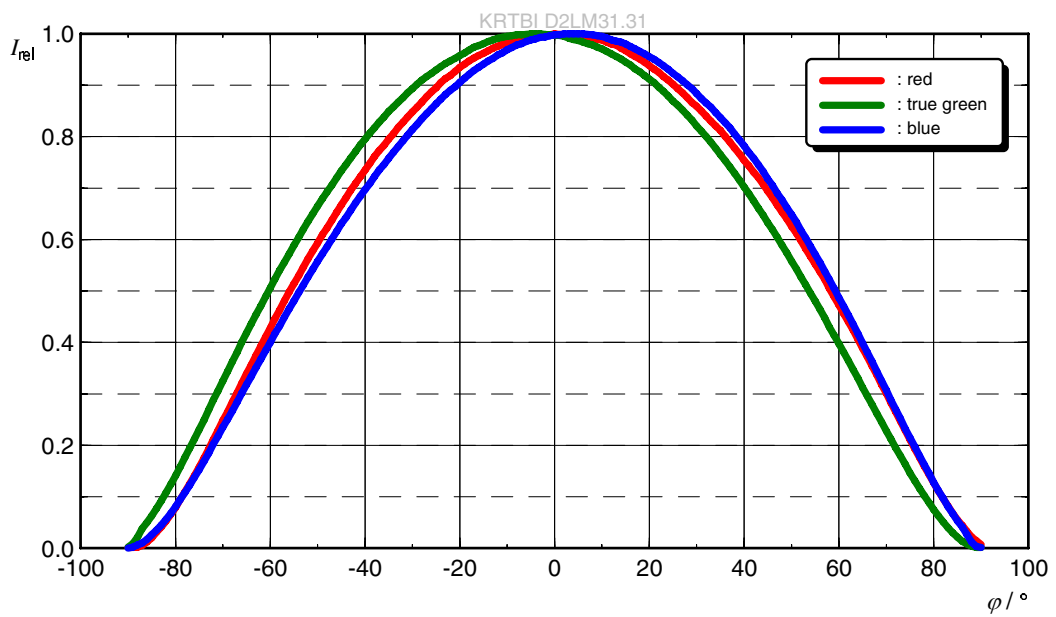

相对发光强度 <sup>5)</sup>

$I_v/I_v(25^\circ\text{C})=f(T_j)$ ; blue

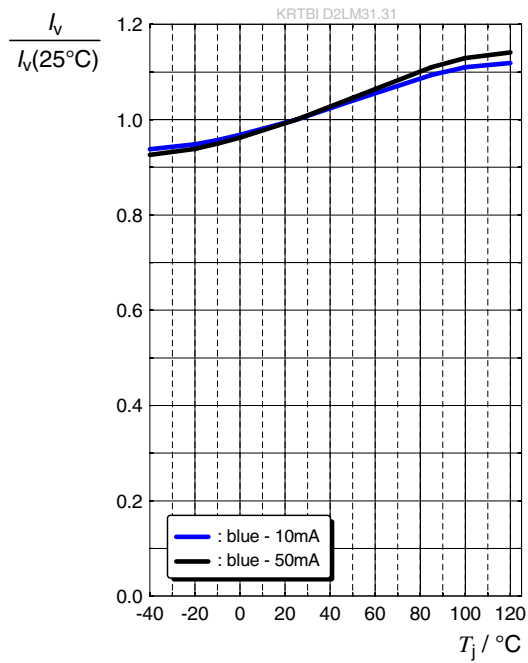

相对发光强度 <sup>5)</sup>

$I_v/I_v(25^\circ\text{C}) = f(T_j)$ ; red

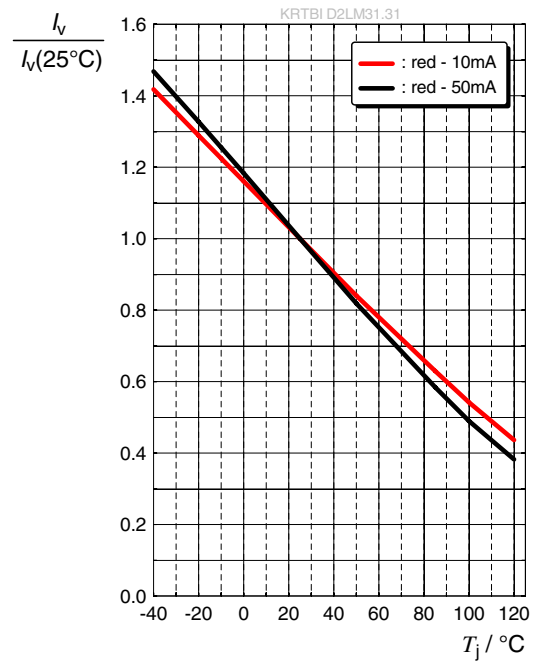

相对发光强度 <sup>5)</sup>

$I_v/I_v(25^\circ\text{C})=f(T_j)$ ; true green

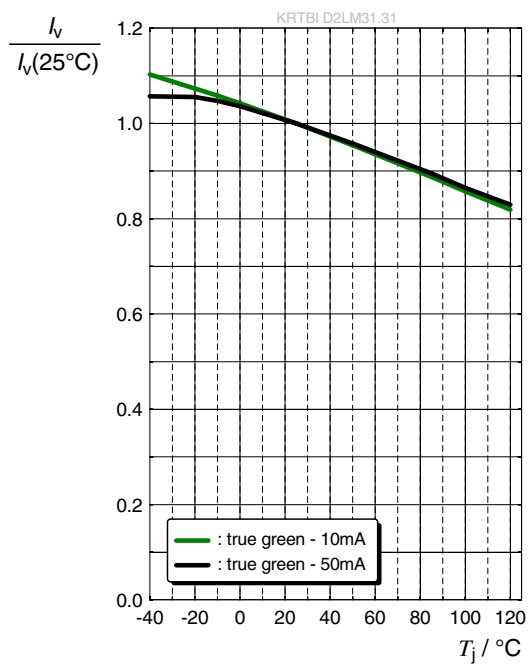

色品坐标偏移 <sup>5)</sup>

$\Delta Cx, \Delta Cy = f(T_j)$ ; blue

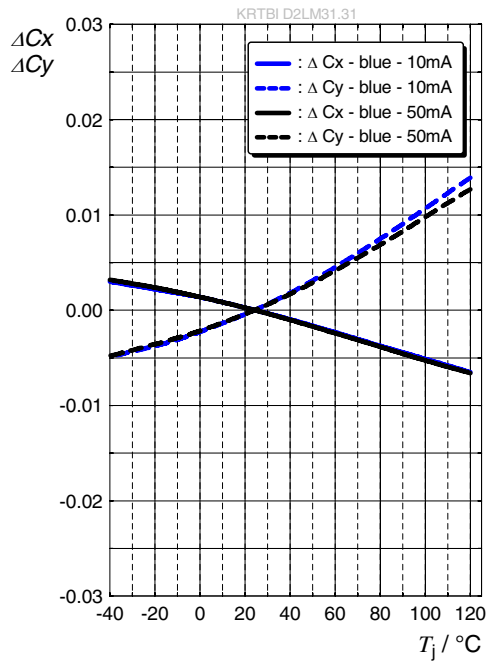

色品坐标偏移 <sup>5)</sup>

$\Delta Cx, \Delta Cy = f(T_j)$ ; red

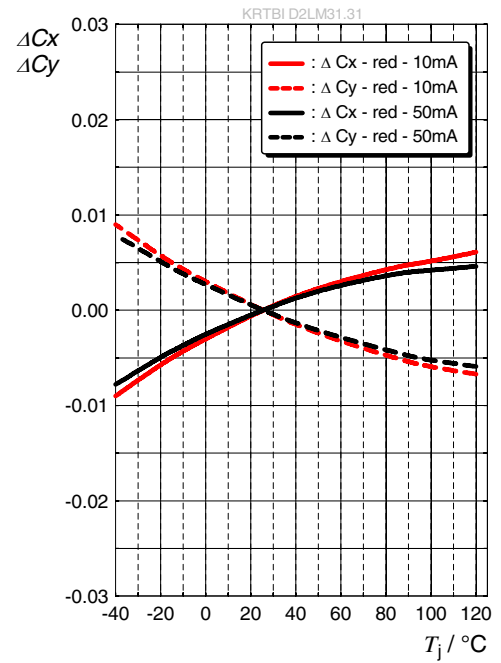

色品坐标偏移 <sup>5)</sup>

$\Delta Cx, \Delta Cy = f(T_j)$ ; true green

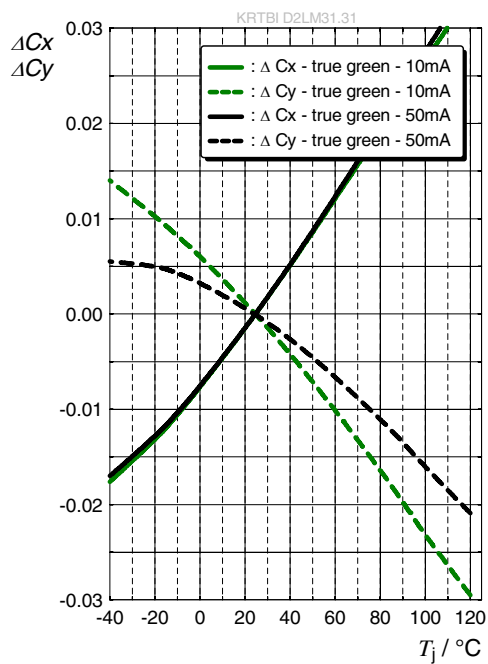

主波长 5)

$$\Delta\lambda_{\text{dom}} = \lambda_{\text{dom}} - \lambda_{\text{dom}}(25^\circ\text{C}) = f(T_j)$$

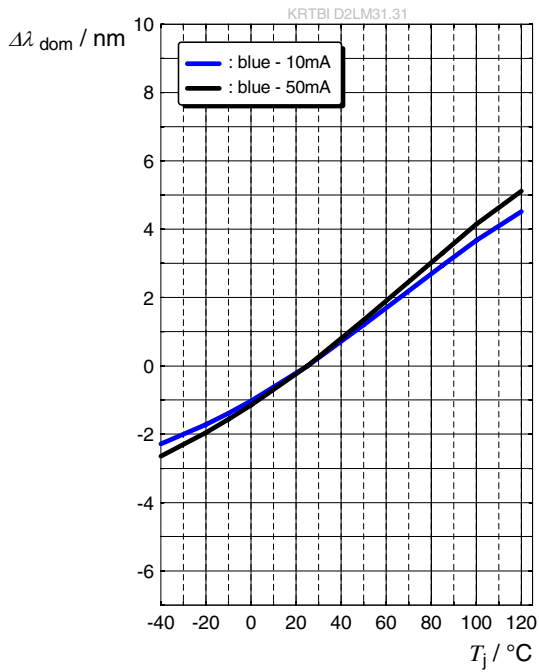

主波长 5)

$$\Delta\lambda_{\text{dom}} = \lambda_{\text{dom}} - \lambda_{\text{dom}}(25^\circ\text{C}) = f(T_j)$$

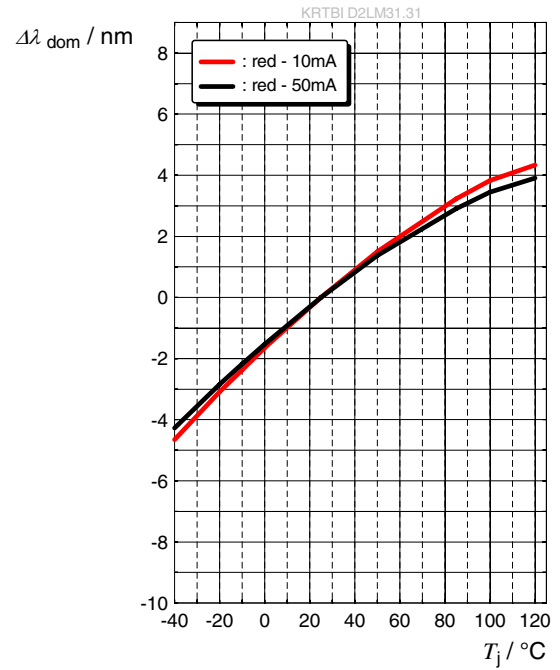

主波长 5)

$$\Delta\lambda_{\text{dom}} = \lambda_{\text{dom}} - \lambda_{\text{dom}}(25^\circ\text{C}) = f(T_j)$$

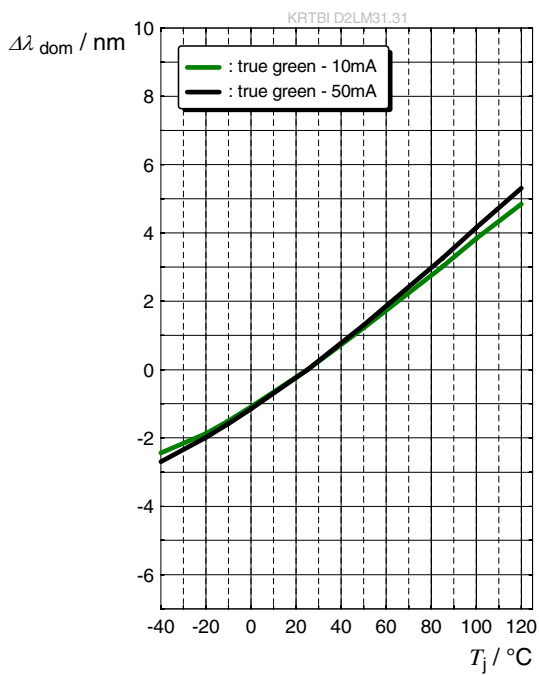

### 容许脉冲处理能力

Day-Mode (I=50mA) or Night-Mode (10mA)

Single-Chip Operation

Duty Cycle (D) = D (red) or D (green) or D (blue)

KRTBI D2LM31.31-0001

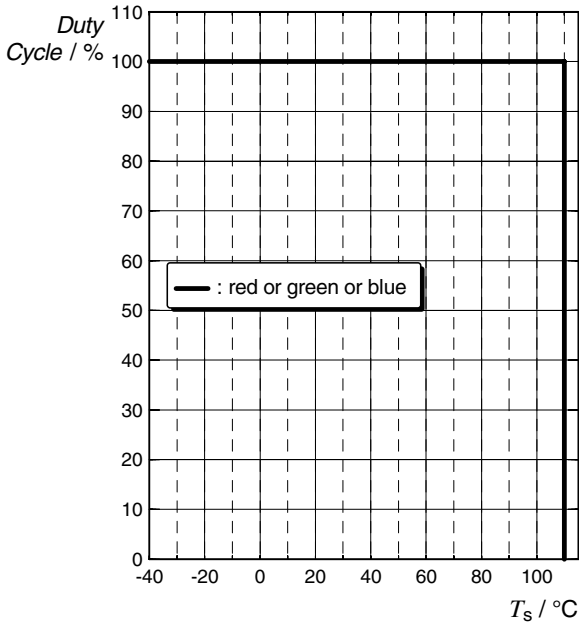

### 容许脉冲处理能力 <sup>4)</sup>

Day-Mode (I=50mA)

Multi-Chip Operation

Duty Cycle (D) = D (red) + D (green) + D (blue)

KRTBI D2LM31.31

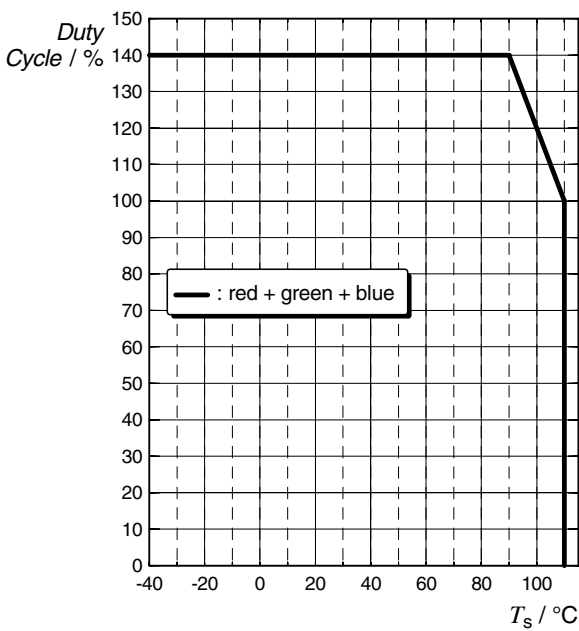

### 容许脉冲处理能力

Night-Mode (I=10mA)

Multi-Chip Operation

Duty Cycle (D) = D (red) + D (green) + D (blue)

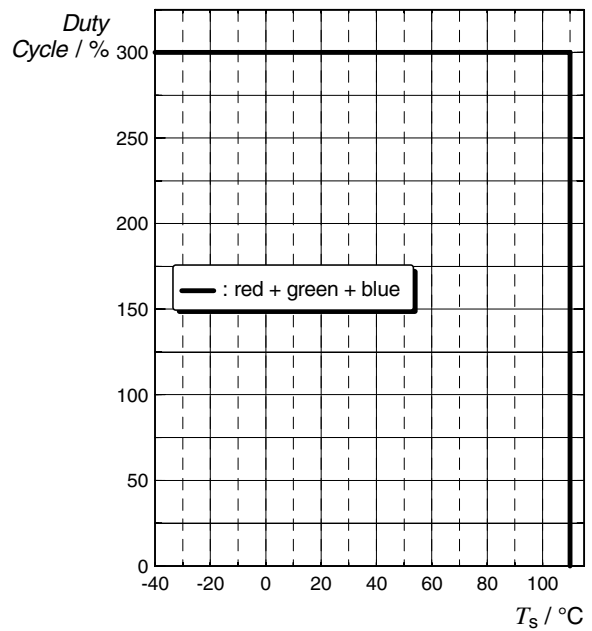

尺寸图 6)

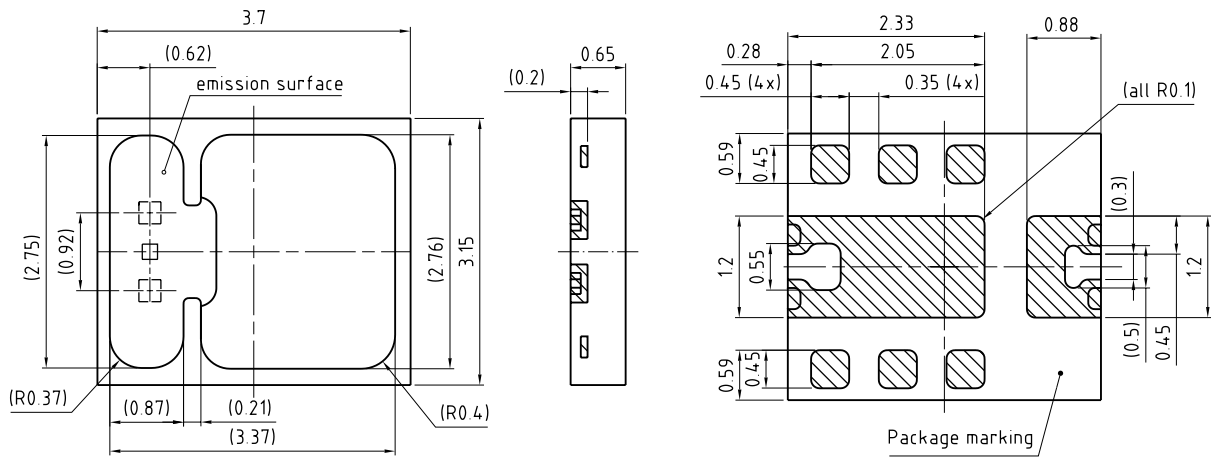

general tolerance  $\pm 0.1$   
lead finish Au

C67062-A0425-A2-01

备注:

近似重量: 22.2 mg

腐蚀试验: 类别: 3B  
测试条件: 40°C / 90 % RH / 15 ppm H<sub>2</sub>S / 14 days (stricter than IEC 60068-2-43)

## 内部电子电路

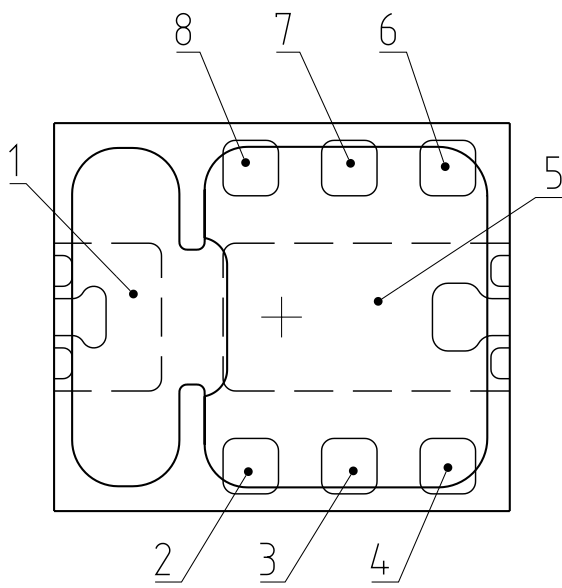

View from top side

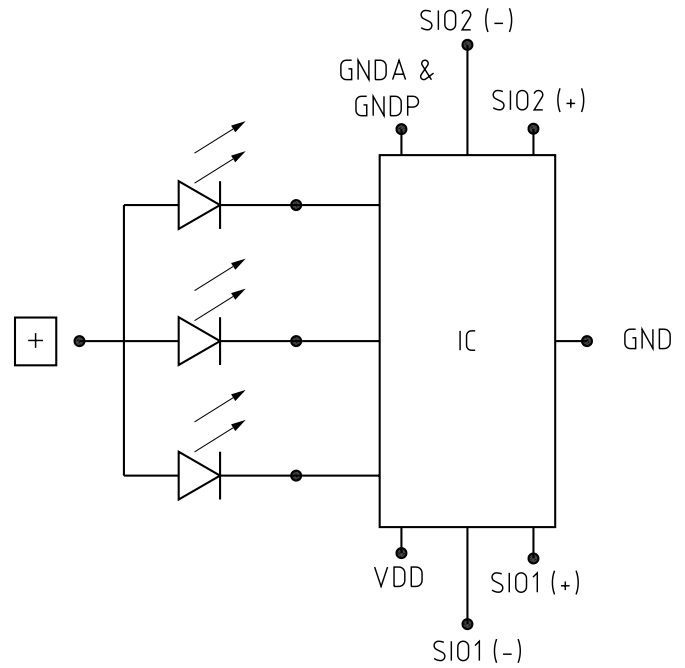

### 识别码

### 描述

识别码	描述
1	VLED
2	VDD (IC)
3	SIO1 (-)
4	SIO1 (+)
5	NA (pull to GND)
6	SIO2 (+)
7	SIO2 (-)
8	GNDA & GNDP

## Application Description

A typ. application is a dynamic ambient light with more than 50 LEDs/PCB.  
 First device in a daisy chain communicates with uC via single-ended interface. In forward direction (MCU -> chain) it is asynchronous Manchester coded signal. In backward direction it is synchronous communication. Device sends messages back to MCU per request only. (Master slave system)  
 Between devices in both directions the communication uses LVDS physical layer and telegrams are also Manchester coded.

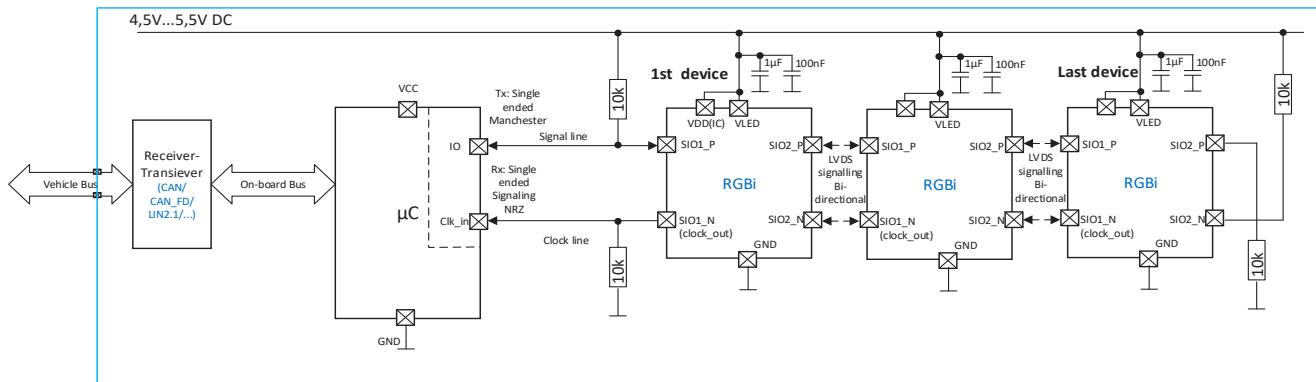

## Application with Transceivers

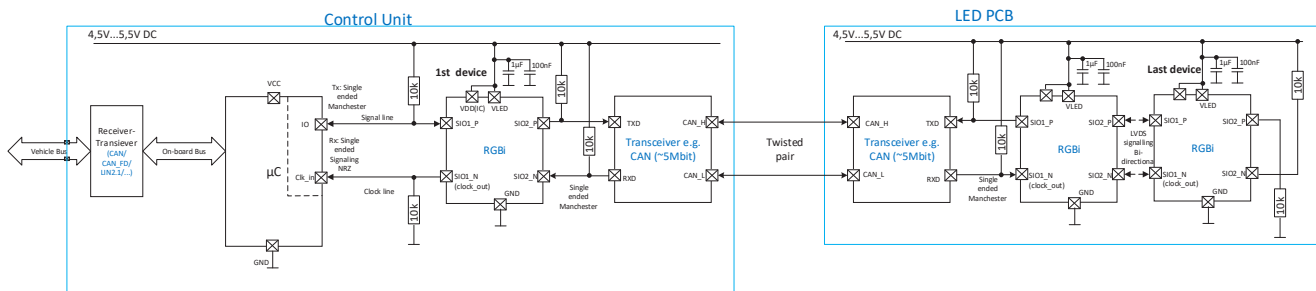

To allow a communication over cable between RGBi devices a connectivity to transceiver e.g. CAN FD via single ended Manchester coded communication is an option. The protocol will not change to a CAN protocol.

## Temperature sensor

The T-sensor is included in the IC device and trimmed at production.  
 The performance is stable over the full temperature range with an 8bit register for readout.  
 Readout is possible during sleep or active device state, the device must be addressed.  
 Calculation ADC value to °C  
 $Temperature [^{\circ}C] = 1.072 \times ADC \text{ readout value} - 126^{\circ}C$   
 Accuracy: +/-5°C within range -40°C - +125°C

## One Time Programming Memory

OTP includes optical measurement data of Red, Green & Blue for 10mA & 50mA. This allows a PWM calculation or calibration of each RGBi within the MCU to achieve a very accurate color setpoint.

Parameter	Comment	Symbol		Values
Optical data size		M_LED_cal	typ.	168 bit
ID size		M_ID		21 bit
VDD voltage range for readout	See VDDGOOD	VDD	min. typ. max	4.5 V 5 V 5.5 V

## Single Ended, LVDS Link and Data Structure

### Overview

- Bi-directional and uni-directional (loop back to master MCU)
- LVDS - differentially Manchester coded
- Single ended – Manchester coded & Manchester decoded (NRZ, clock & data)  
Push-pull interface, clock is invertible
- Communication direction and SIO connection is flexible
- Communication speed is typ. 2,4Mbps Manchester coded

### Communication modes

Each one of the 2 available SIO interfaces do support 4 different modes.

Each SIO only can operate in semi-duplex mode meaning it either does receive or transmit a telegram at the same time. However, it is possible that a device does receive a telegram at one SIO and start transmitting at the other SIO interface.

The 4 communication modes are:

1. “LVDS-mode”: The SIO communication is using LVDS signaling for transmitting and receiving a communication telegram. The bit stream is using Manchester encoding to transfer DATA & CLK on the same line.
2. “MCU-mode-normal”: In this mode a SIO is using single-ended mode for the signaling. Received telegrams are Manchester encoded on SIOx\_P port. For transmitting, the device is decoding the Manchester signal, SIOx\_P will deliver the DATA in NRZ format and SIOx\_N delivers the corresponding clock.
3. “MCU-mode-EOL(EndOfLine)”: This is similar to “MCU mode, normal” but the SIO port does consider itself to be at the end of the daisy chain. This is needed for READ ONLY.
4. “CAN-mode”: In this mode, it is possible to communicate via a CAN FD transceiver. SIOx\_P is always in output state and transmits telegram as Manchester encoded signals (single-ended), SIOx\_N is always in input state and receives telegrams as Manchester encoded signal (single-ended). Due to the Manchester encoding, the CAN FD transceiver needs to support twice the data rate.

## Communication mode selection

Communication mode auto detection takes place during initialization phase via voltage level check on SIOx\_x and this mode cannot be changed during the operation cycle. After a HW Reset (POR) the Initialization with mode selection takes place again.

SIO_P State	SIO_N State	Signal level	RX encoding	TX encoding	SIO_P type	SIO_N type	Application case
		LVDS	Manchester	Manchester	bidirectional	bidirectional	LVDS
pull up	pull down	Single ended	Manchester on SIO_P	Data on SIO_P; Clock on SIO_N	bidirectional	Output or inactive	MCU mode normal
pull down	pull up	Single ended	-	Data on SIO_P; Clock on SIO_N	Output	Output	End of Line, MCU mode EOL
pull up	pull up	Single ended	Manchester on SIO_N	Manchester on SIO_P	Output only	Input only	CAN mode (ext. transceiver)

## Single-ended communication physical layer and bit coding

Single ended communication in the master->slave direction is performed using Manchester encoding. In that case a bit stream is sent via SIOx\_P only; SIOx\_N of the device is ignored. Slave-master communication is performed with NRZ coding. In that case SIOx\_N provides a clock signal. The clock signal is inverted if it's selected via setup register. Communication Data rate effective is typ. 2.4Mbps.

### MCU transmitting – single ended Manchester coded out:

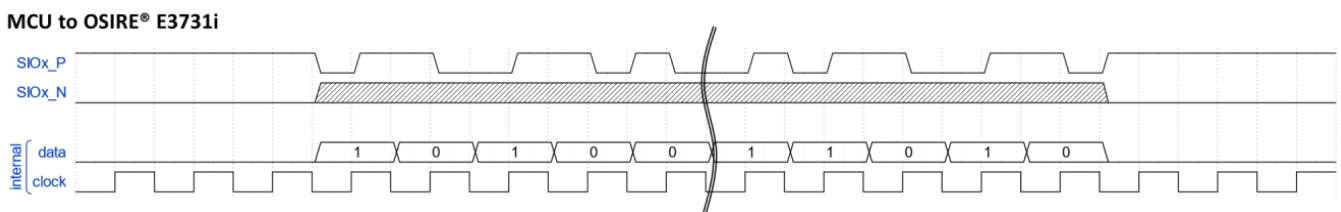

## MCU receiving – single ended Manchester decoded in (NRZ – clock & data receiving)

The receiving clock could be inverted via setup register

OSIRE® E3731i to MCU

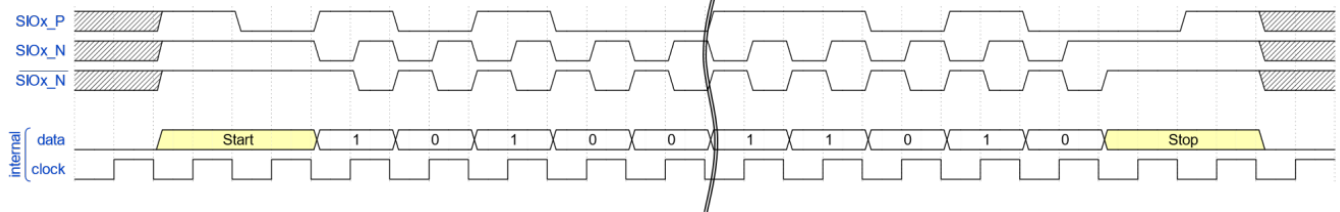

## Transceiver – single ended Manchester coded out & in

CAN to OSIRE® E3731i

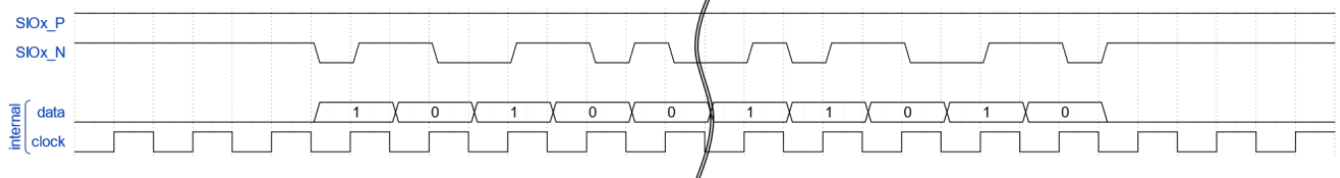

OSIRE® E3731i to CAN

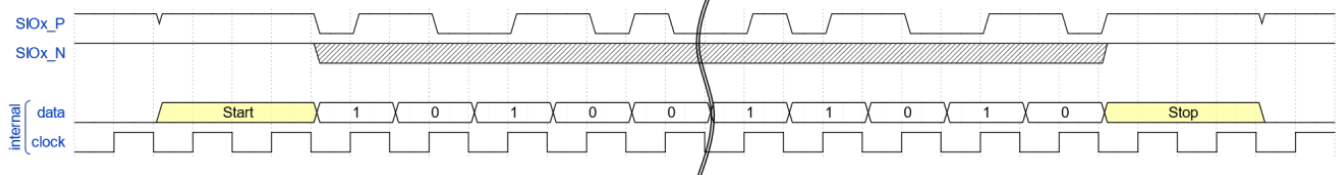

If a transceiver is detected on SIOx the output and input message is via single ended Manchester encoded communication with typ. 2.4 Mbit/s data transfer rate. For the transceiver the data transfer rate depends on the data signal due to the Manchester encoded data. Means up to the double transfer rate is needed (4.8 Mbit/s). Requires a 5 Mbit/s transceiver

## Differential communication physical layer and bit coding

### Physical layer

For differential communication the termination resistance  $R_{term\_LVDS}$  is 200 Ohm, differential voltage  $V_{diff\_LVDS}$  is app. 300 mV, data rate is typ. 2.4 Mbps. Common mode voltage is typ. 1.2 V, it means the max voltage on the communication lines during communication is typ. 1.35 V and the min. voltage is typ. 1.05 V

#### OSIRE® E3731i to OSIRE® E3731i

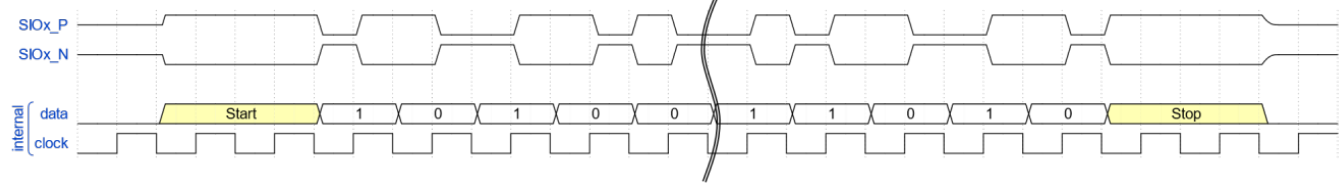

## Physical layer parameters

Parameter	Symbol	Comment		Values
Threshold on SIOx_x to detect communication mode (high)	V_th_se_high	Detection via pull up to VCC (typ.10k)	min.	2.85 V
Threshold on SIOx_x to detect communication mode (low)	V_th_se_low	Detection via pull down to GND (typ10k)	max.	0.7 V
Output low level for pin SIOx_P and SIOx_N for single-ended communication	V_SIOx_P/N(O,L)		max.	0.7 V
Output high level for pin SIOx_P and SIOx_N for single-ended communication	V_SIOx_P/N(O,H)		Min.	VDD - 0.7 V
data rate for slave->master direction (internally generated)	f_com_int		typ.	2.4 Mbps
Clock period for single ended communication Manchester decoded device			typ.	417 ns
data rate for MCU ->slave communication	f_com_m		min. typ. max.	2.21 Mbps 2.40 Mbps 2.59 Mbps
Minimum time between two messages with same address parity (even-even or odd-odd, incl. broadcast, sent from MCU, end-to-start, 80 bits telegram length)*		100 nodes		11.8 $\mu$ s
		200 nodes		12.1 $\mu$ s
		500 nodes		12.7 $\mu$ s
Minimum time between two messages with opposite address parity (even-odd or odd-even, sent from MCU, end-to-start, 80 bits telegram length)*		100 nodes		14.2 $\mu$ s
		200 nodes		16.9 $\mu$ s
		500 nodes		24.7 $\mu$ s

\*Note: The wait time depends on chain length M and telegram length N as

$t_{\text{same parity}} = 7.79 + 0.042 N + 0.0671 \sqrt{M}$  ( $\mu$ s) and  $t_{\text{different parity}} = 7.79 + 0.042 N + 0.0671 \sqrt{M} + 0.024 M$  ( $\mu$ s), respectively

High level input voltage single ended communication	Vin_high_se	CMOS logic	min.	2.0 V
Low level input voltage for single ended communication	Vin_low_se	CMOS logic	max.	0.8 V
LVDS common mode voltage with active communication	V_LVDS_com		typ.	1.2 V
LVDS common mode voltage with no active communication	V_LVDS_off		typ.	0
LVDS differential voltage	V_LVDS_diff		typ.	300 mV
LVDS termination resistance	R_LVDS	Included in IC	typ.	200 Ohm
LVDS Tx current	I_LVDS_TX		typ.	1.5 mA
Max number of addresses	Max_address		typ.	1000

### Transceiver connectivity typ. CAN FD

Parameter	Symbol	Comment	Values	
Data rate for CAN-FD communication			min.	2.31 Mbps
			typ.	2.40 Mbps
			max.	2.52 Mbps
Allowed duty cycle variance on receiver	DUTY <sub>RX</sub>		min.	40 %
			max.	55 %
Duty cycle variance on transmitter	DUTY <sub>TX</sub>		typ.	50 %

## Constant current LED drivers

### Overview

- 3 channel constant current LED drivers (high stability over full temperature range)
- PWM controlled
- 15bit PWM engine
- 500 Hz & 1000 Hz mode

### Description

There are 3 integrated current sink drivers to activate three LED's. The drivers can be set for 2 current settings via command. The current drivers are controlled by a PWM with a frequency of 500 Hz or 1000 Hz. Received PWM setting is latched till the next PWM command. Current driver activation is performed with phase shift to avoid high di/dt.

Parameter	comment	Symbol	Values	
Peak current setting 1	“nightmode” set via PWM command	I_dr_1	min.	9.5 mA
			max.	10.5 mA
Peak current setting 2	“daymode” set via PWM command	I_dr_2	min.	47.5 mA
			max.	52.5 mA
PWM frequency 1	Set by setup register	f_dr_1	min.	500 Hz
PWM frequency 2	Set by setup register	f_dr_2	min.	1000 Hz
PWM frequency accuracy		f_tol	min.	-5 %
			max.	5 %
PWM resolution 1	For f_dr_1	PWM_1		15 bit
PWM resolution 2	For f_dr_2	PWM_2		14 bit
Min PWM value	Recommended for open/short detection	PWM_value	min.	64 LSB
Rise time 1 (default)	For I_dr_1 (typ. 10mA)	t_rise_1	typ.	50 ns
Fall time 1 (default)	For I_dr_1 (typ. 10mA)	t_fall_1	typ.	50 ns
Rise time 2 (default)	For I_dr_2 (typ. 50mA)	t_rise_2	typ.	50 ns
Fall time 2 (default)	For I_dr_2 (typ. 50mA)	t_fall_2	typ.	50 ns
Phase shift between driver LED1(Red), LED2(Blue) and LED3(Green) current sink.		phase_shift_sink	typ.	1/3 period

推荐焊盘 6)

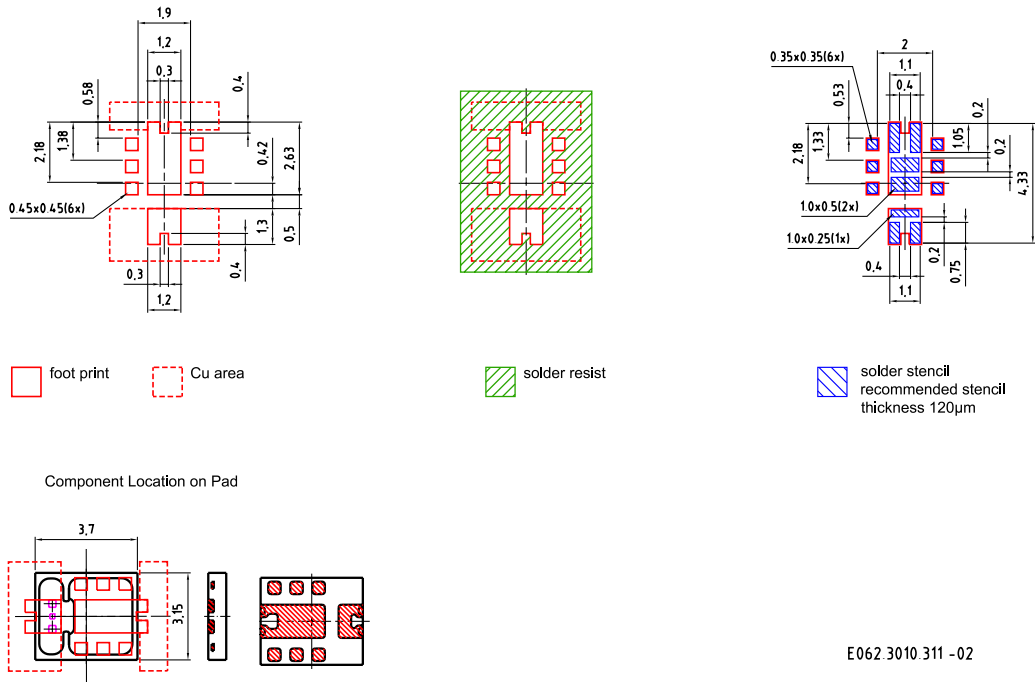

E062 3010 311 -02

为了获得最佳的焊点连接效果，我们建议在标准氮气环境下进行焊接。封装不适合超声波清洁。

### 回流焊曲线

根据JEDEC J-STD-020E, 产品符合MSL等级 2

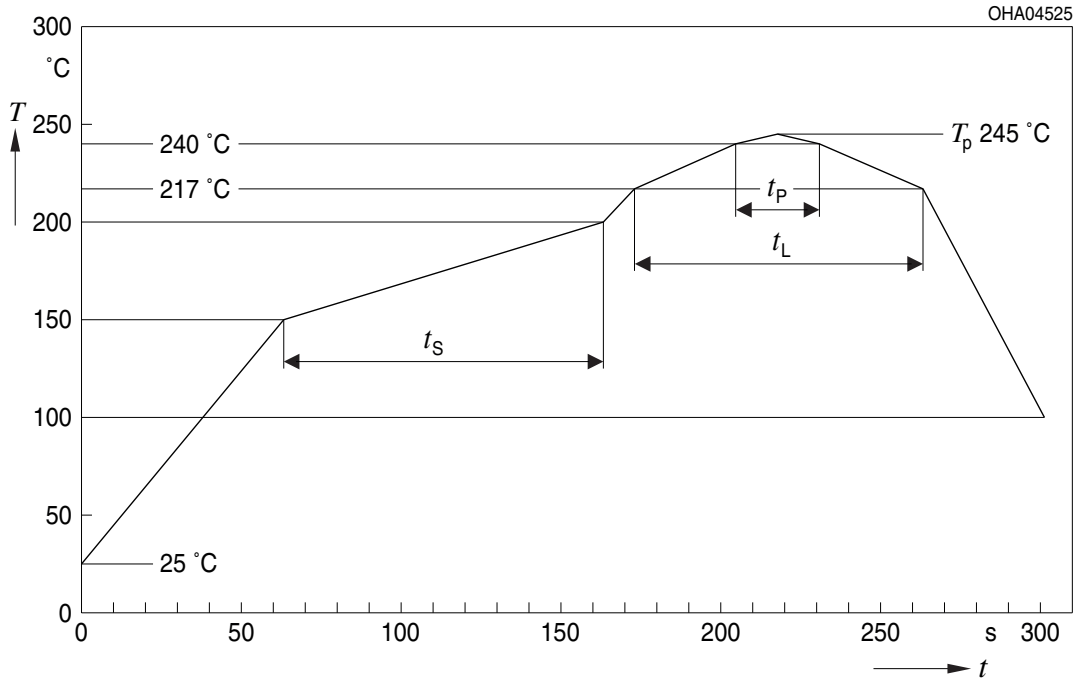

曲线特征	符号	无铅组装			单位
		最小值	推荐值	最大值	
预热升温速率 <sup>1)</sup> 25 °C 至 150 °C			2	3	K/s
时间 $t_s$ $T_{Smin}$ 至 $T_{Smax}$	$t_s$	60	100	120	s
峰值升温速率 <sup>1)</sup> $T_{Smax}$ 至 $T_p$			2	3	K/s
液相线温度	$T_L$		217		°C
超过液相线温度的时间	$t_L$		80	100	s
峰值温度	$T_p$		245	260	°C
温度保持在指定峰值温度 $T_p - 5$ K 的 5 °C 范围内的时间	$t_p$	10	20	30	s
降温速率* $T_p$ 至 100 °C			3	6	K/s
时间 25 °C 至 $T_p$				480	s

所有温度均指从元件顶部测得的封装中心温度  
\* 斜率计算  $DT/Dt$ :  $Dt$  最大值为 5 s; 涵盖整个 T 范围

编带机 6)

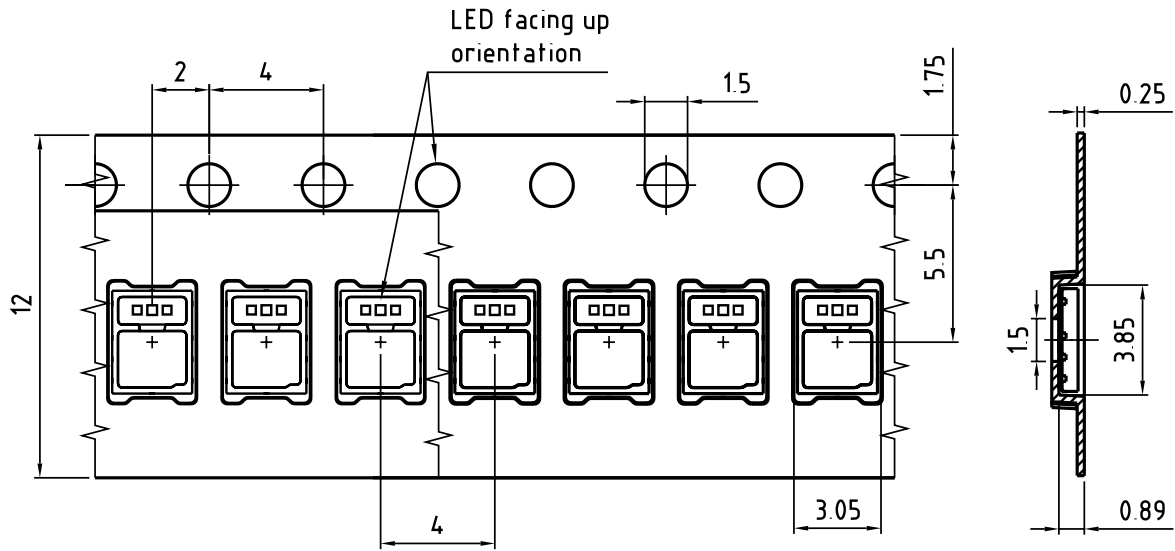

C67062-A0387-B2-03

编带和卷带 <sup>7)</sup>

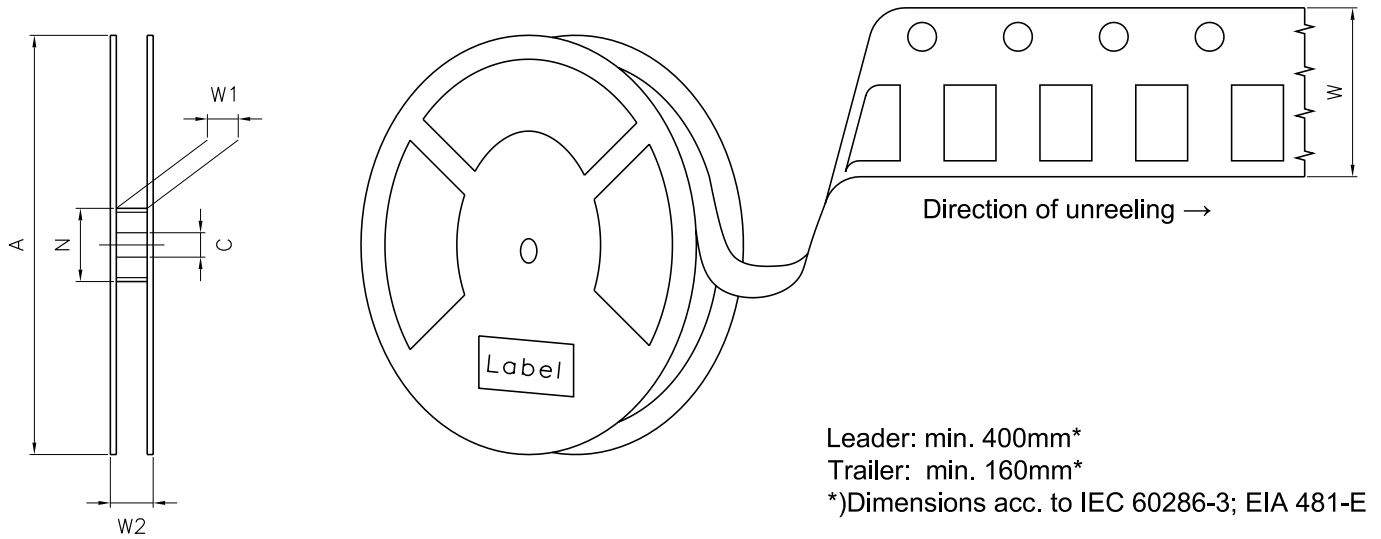

盘尺寸

A	W	$N_{\min}$	$W_1$	$W_{2\max}$	每卷带上的数量
180 mm	$12 + 0.3 / - 0.1$ mm	60 mm	$12.4 + 2$ mm	18.4 mm	2000

条形码-产品-标签 ( BPL )

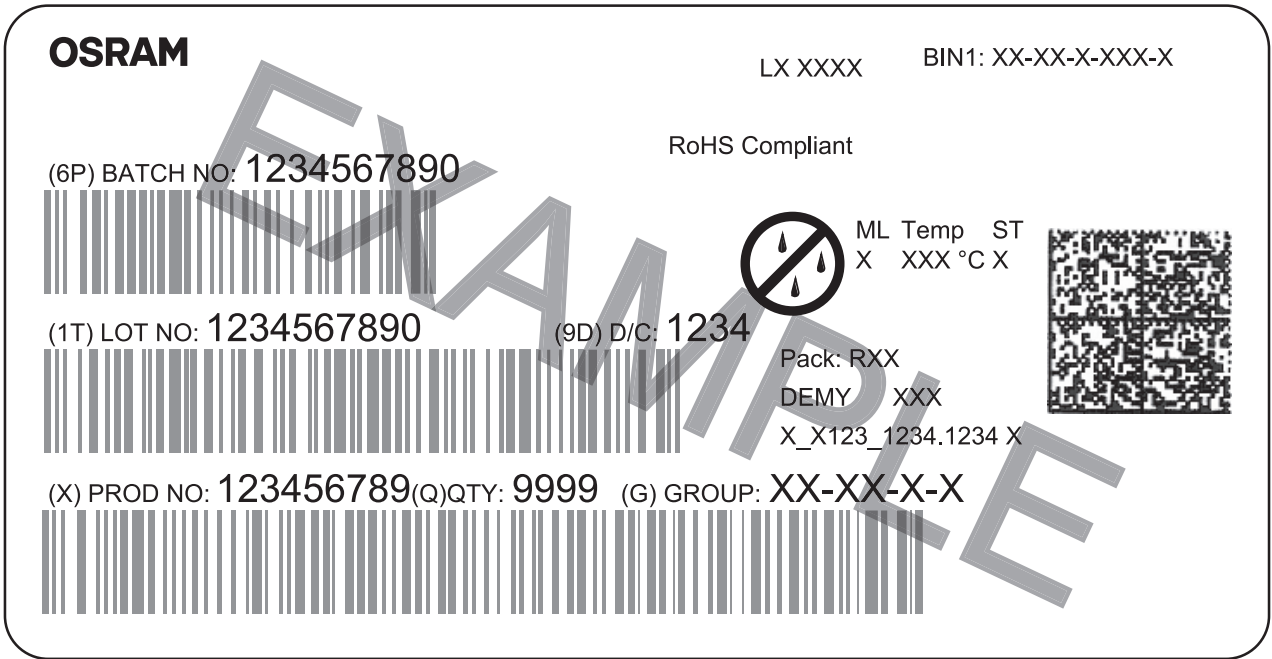

干燥包装工艺和材料 <sup>6)</sup>

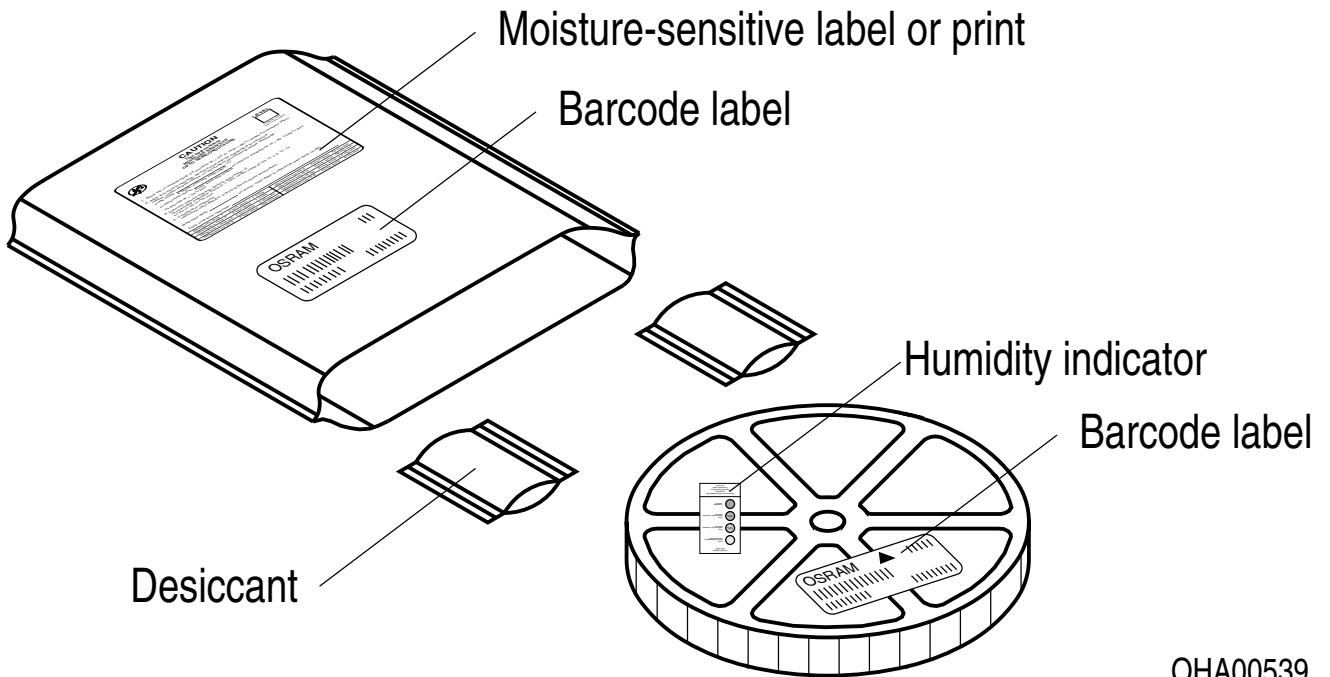

根据JEDEC-STD-33,湿敏产品包装在一个干燥的袋子中, 包含干燥剂和湿度卡.

## 备注

人眼安全的评估按照IEC 62471:2008标准(photo biological safety of lamps and lamp systems)进行。在本CIE标准的风险分组系统中，本数据表中指定的LED属于该类 **低风险 (暴露时间 100 s)**。在某些情况下(如不同的暴露时间、瞳孔大小、观察距离等)，尽管这些产品对人眼没有危害。但是理论上来说，由于强光光源的致盲作用，它们具有很高的二次曝光可能性。例如当注视其他明亮的光源(如前照灯)时，也会出现视力暂时下降和余像情况，也可能会导致不同程度的急躁、恼怒、视力受损等情形。

除其他物质外，该器件的子组件还包含金属填充材料，包括银。金属填充材料可能会受到含残留侵蚀性物质的环境的影响。因此，我们建议客户在存储、生产和使用过程中尽量少将器件暴露于腐蚀性物质环境中。当使用上述测试条件进行测试时，器件在规定的测试持续时间内表现出了颜色的变化，但其各项性能的变化均未超出失效极限的定义。IEC60810中描述了相关的各项失效极限。

更多的应用信息，请访问 <https://ams-osram.com/support/application-notes>

## 免责声明

### 语言

如中、英文文本描述有任何差异或偏差，以英文文本为准。

The English version of this document will prevail in case of any discrepancies or deviations between the Chinese and English document.

### 请注意!

该信息仅描述了组件的类型，不能视为对组件特征的保证。本公司保留对交付条款和设计更改的权利。由于技术要求，组件可能含有危险物质。

如需咨询相关类型的信息，请联系我们的销售组织。

如需打印或下载，请自行在我们网站上寻找最新版本。

### 包装

请使用您所知的回收操作员。我们亦可帮助您与离您最近的销售办事处联系。

若双方另行存在协议，在您事先对包装材料已进行分类的前提下，我们亦可回收包装材料，但贵方必须承担运输费用。对于退回给我们的包装材料，若未事先分类或我司并无义务接收的，我们将向您收取相关回收费用并开具发票。

### 产品安全设备/应用或医疗设备/应用

我们的组件并非开发、构建或测试用作安全相关组件或应用于医疗设备，亦不适格适合在该等设备的模组或系统层面使用。

如果买方或买方供货的终端客户考虑在产品安全设备/应用或医疗设备/应用中我们的组件，买方和/或客户必须立即通知我们的当地销售伙伴，由我方和买方和/或客户将就客户的特定需求进行分析和协调。

## 词汇表

- 1) **亮度:** 亮度值在持续15毫秒，IC所能驱动的最大PWM频率的脉冲电流下测得，内部再现性±8%，扩展不确定度±11%（依据GUM法覆盖系数K=3的不确定度测量）
- 2) **波长:** 波长值在持续15毫秒，IC所能驱动的最大PWM频率的脉冲电流下测得，内部再现性±0.5 nm，扩展不确定度±0.1 nm（依据GUM法覆盖系数K=3的不确定度测量）
- 3) **反向工作:** 并非设计用于反向工作。连续反向工作会导致器件迁移和损坏。
- 4) **热电阻:** Rth max以统计值（ $6\sigma$ ）为基础。
- 5) **典型值:** 由于半导体器件制造工艺的特殊条件，技术参数的典型数据或计算相关性只能反映统计数字。这些参数不一定对应每个产品的实际参数，可能不同于产品的典型数据和计算相关性或典型特性线。如有要求（例如由于技术改进），这些典型数据会被更改，恕不另行通知。
- 6) **测量公差:** 除非图纸中另有说明，公差表示为±0.1，尺寸表示为mm。
- 7) **编带和卷料:** 所有尺寸和公差均遵循IEC 60286-3，单位为mm。

## 修订历史

版本	日期	修改
1.0	2023-07-26	初始版本
1.1	2025-04-28	订货办法 色度坐标组 描述 特征 降额图表 亮度组
1.2	2025-04-30	特性



EU RoHS and China RoHS compliant product

此产品符合欧盟 RoHS 指令的要求；  
按照中国的相关法规和标准，  
不含有毒有害物质或元素。

**Published by ams-OSRAM AG**

Tobelbader Strasse 30, 8141 Premstaetten, Austria

Phone +43 3136 500-0

[ams-osram.com](http://ams-osram.com)

© All rights reserved

**am** 

**OSRAM**